

TD Pilot

Getting Started Guide

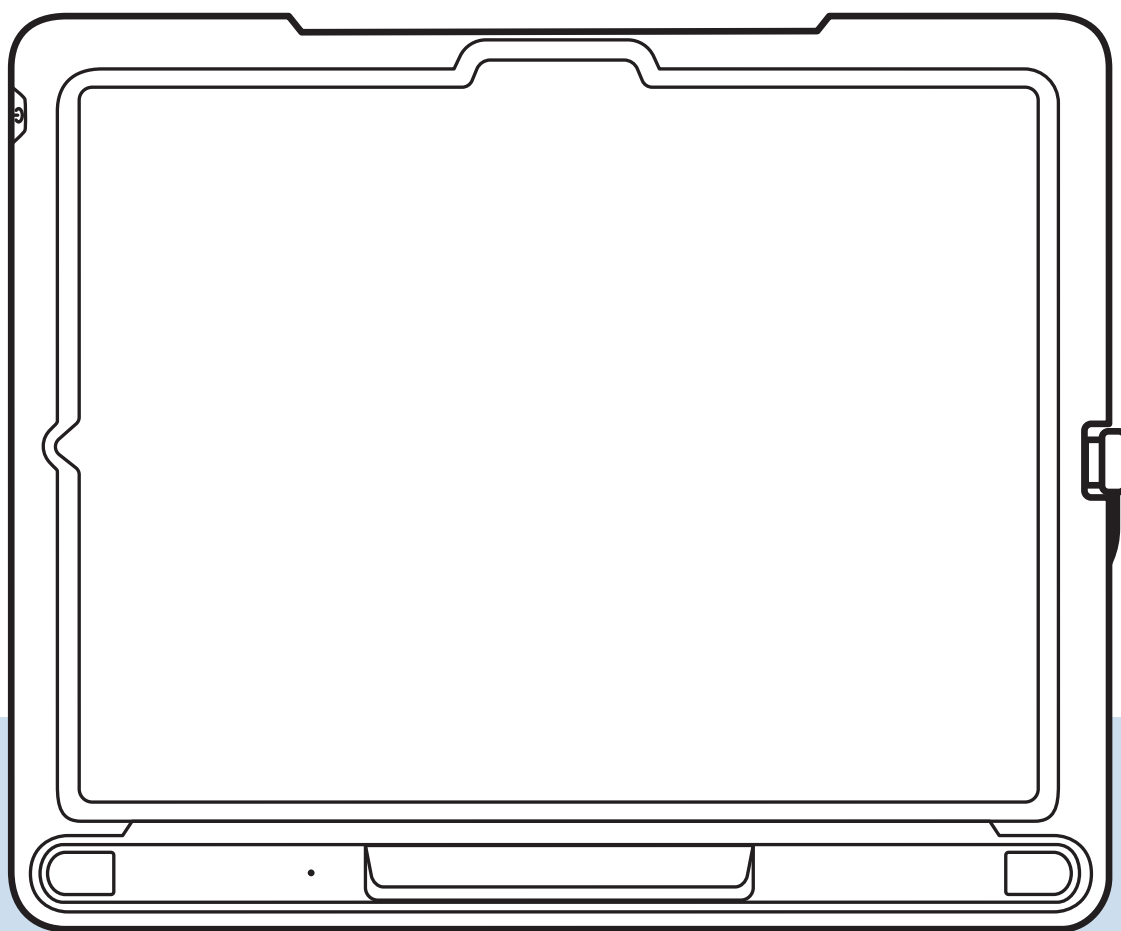

Scan the QR code to view this document
in all available languages on the web.
qrco.de/PilotDocs

What's included

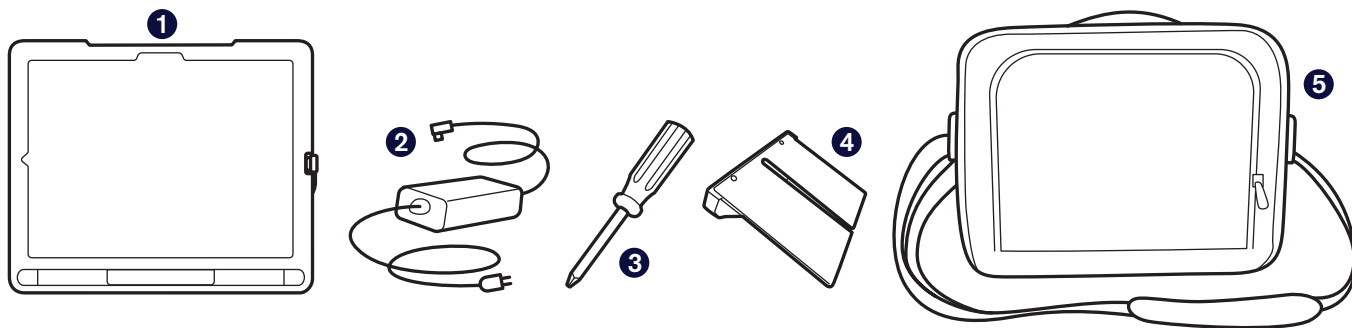

1 TD Pilot device

2 Charger with cable

For use only with power supply NGE60-TD

3 Screwdriver

4 Adjustable bracket

5 Carrying case

Get to know your device

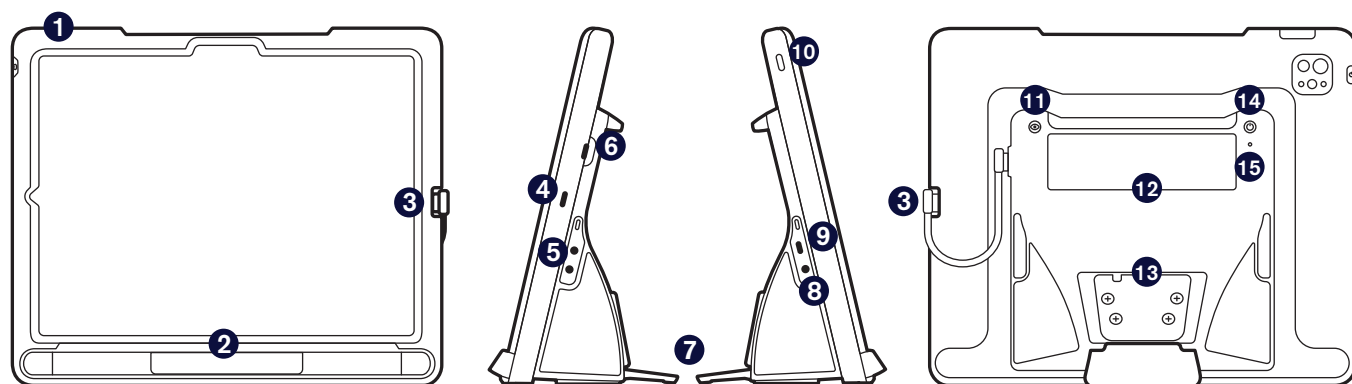

Front

Sides

Back

1 Volume Buttons

2 Eye Tracker:

3 USB-C cable

4 iPad charging port

5 Switch Ports

6 USB-C connector (internal)

7 Foldable leg

8 Audio jack port

9 Power Connector

10 iPad power button

11 Track Status Button

12 Partner Window

13 Mounting Plate

14 TD Pilot power button

15 Status LED

Let's get started

This Getting Started Guide is designed for two people: the person who will use the device to communicate and a helper who can touch the screen and move the device. The sections with the hand icon must be completed by the helper. The sections with the eye icon should be completed by the AAC user.

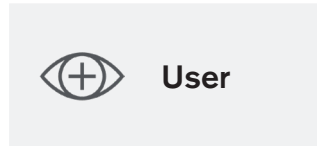

Power on

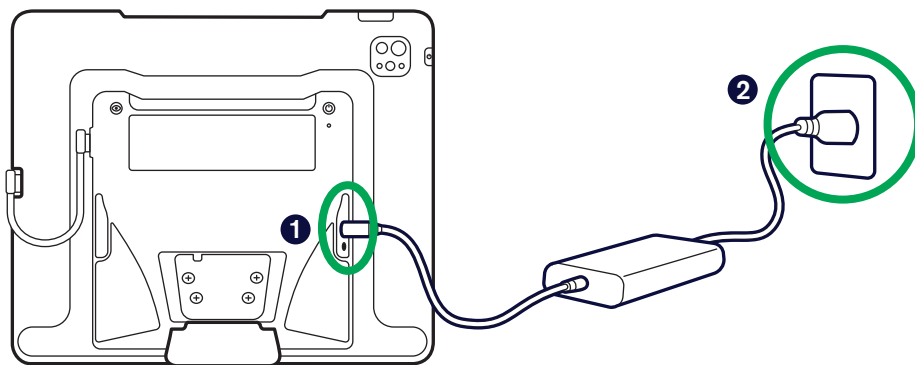

- 1 Open the protective cover over the ports and connect the charger USB-C cable.
- 2 Plug the power supply into an outlet. TD Pilot will start up automatically.



TD Pilot power management

When the TD Pilot is powered on, the eye tracker is always active, even when the iPad screen is locked. Because of this, the batteries will drain when the TD Pilot is turned on and not connected to external power. It is best to leave the TD Pilot plugged into the charger whenever you are not using it.

Battery status information is found in *TD CoPilot* > *Settings* > *Battery*.

Additional information about power management is available in the TD Pilot User's Manual.

iPad setup

Follow the on-screen prompts to set up the iPad. In order to receive the Tobii Dynavox software included with your purchase, you will need to make the following selections during setup:

- 1 Select your language and region.
- 2 Choose **large** text size.
You may be prompted to customise your Written and Spoken Languages settings. Choose based on your personal preference.
- 3 On the Quick Start screen select **Set Up Without Another Device** or **Set Up Manually**.
- 4 Join a Wi-Fi network, then select **Next**.
- 5 On the Data & Privacy screen select **Continue**. If prompted to transfer your apps and data, select **Don't Transfer Anything**.
- 6 On the Remote Management screen select **Enroll this iPad**.



Warning

Do NOT select Remove iPad from Organisation. If this option is selected, you will not receive your communication apps and the device will have to be sent back to Tobii Dynavox to resolve the issue.



Note

Remote management, also known as MDM, allows Tobii Dynavox to send software and software updates to your iPad over Wi-Fi. Through remote management Tobii Dynavox will only have access to information about your iPad hardware specifications, OS version, installed apps, and security settings. Tobii Dynavox will not be able to access your personal files, photos, cameras, microphones, or location data.

- 7 If prompted to set up Face ID, feel free to set it up or skip it for now and set it up later in Settings.
- 8 Setting up a Passcode is optional. If you skip it now, you can set it up later in Settings.
- 9 If prompted for an Apple ID, enter the Apple ID for the user, not a caregiver. If you want to skip entering an Apple ID for now, select **Forgot password or don't have an Apple ID?** then **Set Up Later in Settings**.
- 10 Agree to the Apple Terms and Conditions.
- 11 Answer the remaining setup prompts based on your personal preferences.

When you have completed the iPadOS setup prompts, you will see the Home screen containing your app icons.



Note

A popup message will appear at some point asking if you are connecting a pair of headphones. Select **Other Device**.

Set up eye gaze access



Configure the display for gaze accuracy

- 1 Tap **Settings**.



- 2 On the left side, tap the **Display & Brightness** category.
- 3 On the right, tap **Dark**.
- 4 On the right side, scroll down and tap **Display Zoom**.
- 5 Select **Larger Text**.
- 6 Select **Use Zoomed**, then select **Done**.



Set up AssistiveTouch

- 1 On the left side, tap **Accessibility**.
- 2 On the right side, tap **Touch**.
- 3 Tap **AssistiveTouch**, then turn it on.

Eye gaze is now enabled. You will see the Pointer, which shows the location of your eye gaze. The AssistiveTouch menu button also appears on the screen.



- 4 Drag the AssistiveTouch menu button to the top third of the screen on the right side.



What does AssistiveTouch have to do with eye gaze?

AssistiveTouch is designed for people who have difficulty touching the screen. The AssistiveTouch menu allows you to do “touch” functions, such as tap and scroll, using eye gaze. It also provides gaze-accessible shortcuts to things like the Home screen and App Switcher, which are typically accessed through gestures.



Customise the AssistiveTouch Menu

- 1 On the right side, select **Customise Top Level Menu**.
- 2 Tap **+** to change the number of icons to 8.
- 3 Tap **Notification Centre**.
- 4 Swipe to the bottom of the list and tap Toggle **Pause/Resume Dwell**. Tap outside the list to close it.
- 5 Tap the **Gestures** button.
- 6 Swipe to and then tap **Move Menu**. Tap anywhere outside the menu to close it.
- 7 Continue editing the menu icons until your menu matches the one shown to the right.

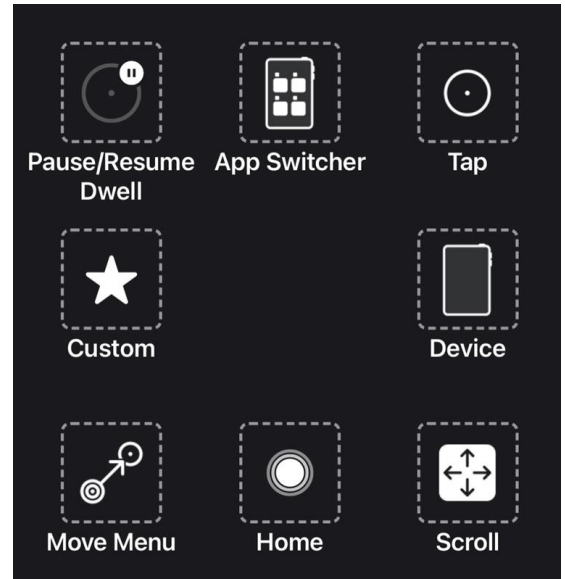

Configure Dwell Control

- 1 On the left, select **Accessibility**.
- 2 On the right, select **Touch**.
- 3 On the right, select **AssistiveTouch**.
- 4 On the right side, swipe to the bottom of the AssistiveTouch menu. Turn on **Dwell Control**. If you are prompted to customise the AssistiveTouch Top Level Menu, tap **No**.



Tip

The default dwell time is 1.5 seconds. You can change the dwell time setting later to suit your needs.



Enable eye gaze when TD Pilot is locked

- 1 On the left, select **Face ID & Passcode**.
- 2 Enter your passcode.
- 3 Swipe to the bottom and turn on **Accessories**.



Waking and Unlocking Your TD Pilot

TD Pilot wakes automatically when the eye tracker detects the user's eyes. Unlock the TD Pilot by selecting the AssistiveTouch Button, then Home.

Try it now:

- 1 Press the top button to lock the TD Pilot.

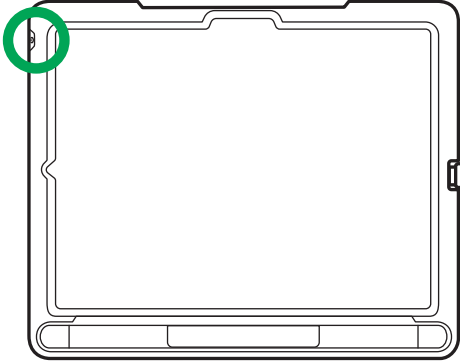

- 2 Look at the screen for a few moments. The TD Pilot wakes and displays the lock screen.
- 3 Tap or use your eyes to select the **AssistiveTouch** menu button then select **Home**.



The TD Pilot is now unlocked.



Tip

If you are interested in extra security on your device, we recommend using Face ID. Face ID allows you to unlock your device without entering a passcode each time. Set up Face ID in *iPadOS Settings > Face ID & Passcode*.





Choose and set up your communication app

**Note**

If the Settings app is open, swipe up from the bottom of the screen to close the app.

- 1 Use the table below to identify the communication app that best suits the user.
- 2 Launch your chosen app and follow the prompts to create a new user or restore an existing user.

	 TD Snap®	 TD Talk
Description	TD Snap is a speech generating app for those who need symbol support.	TD Talk is a speech generating app for people who are literate and do not need supporting symbols.
Composing messages	Messages are composed using word and phrase buttons with supporting symbols. An on-screen keyboard with word prediction is also available.	Messages are composed using an on-screen keyboard with word and phrase prediction, similar to SMS texting.
Literacy level	Emergent through advanced	Advanced
Ages	All ages	Teen to adult
Self-regulation supports	Yes	No

Mount and Position

Prepare the user to start using eye tracking by positioning them comfortably. If they use glasses, make sure that they are wearing them and that the lenses are clean.



Place TD Pilot on your mounting system or a stable surface in front of the user at, or slightly below, their eye level. If their head is tilted left or right, tilt the device to match. It is important that the angle of the screen surface match the angle of the user's face. Most users, when seated at a table or desk, will need to have the device positioned higher than the table surface.

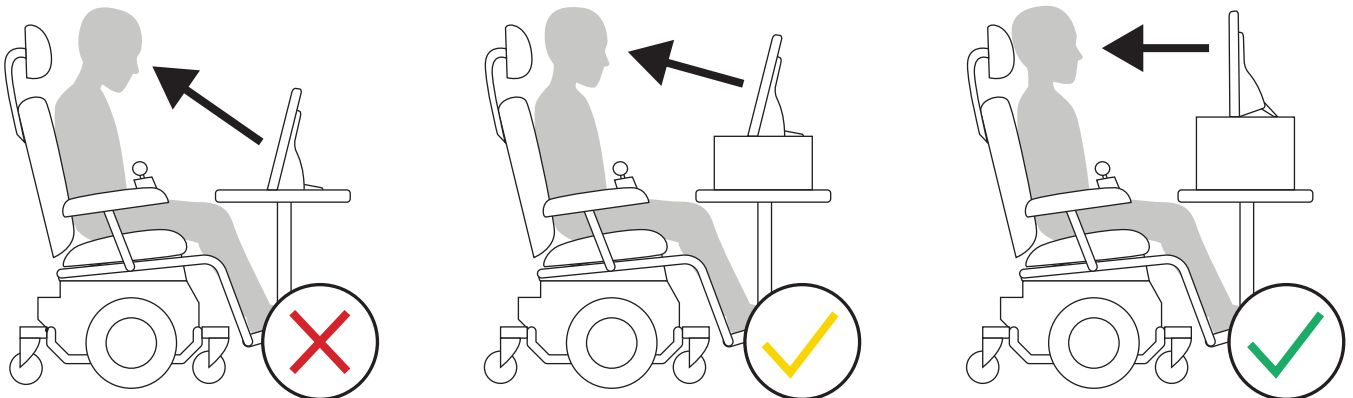

You may need to refine the position of the device during the calibrate steps on the next page. Always adjust the position of the device to suit the user, not the other way around.

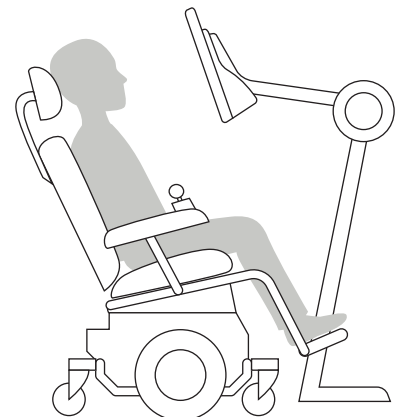

Note

A mounting system is the best option for precise device positioning that is easy to adjust throughout the day. Several mounting options are available, including floor, desk, and wheelchair mounts. Visit [TobiiDynamox.com](https://www.tobii.com) or contact your local Tobii Dynamox partner.

Calibrate



Note

If TD Snap® or TD Talk is open, swipe up from the bottom of the screen to close the app.

- 1 Tap the **TD CoPilot** app.



- 2 Follow the on-screen instructions in CoPilot to calibrate the eye tracker to the user's eyes.
- 3 When the user has finished calibrating, swipe up from the bottom of the screen to return to the Home screen.



Tip

Use the App Switcher in the AssistiveTouch menu to switch between open apps.



Learn, practice, and troubleshoot

Your TD Pilot is now ready to use! Feel free to start exploring your device and apps. When you are ready to learn more, scan the QR codes below to get the TD Snap® Basics Training Cards and TD Talk for iPadOS and AssistiveTouch Training Cards. They show you how to use the main features of your communication apps, grow AAC skills, and troubleshoot issues.



**TD Snap Basics
Training Cards**

qrco.de/bdPliQ



**TD Talk for iPadOS and
AssistiveTouch Training Cards**

qrco.de/bdzoal

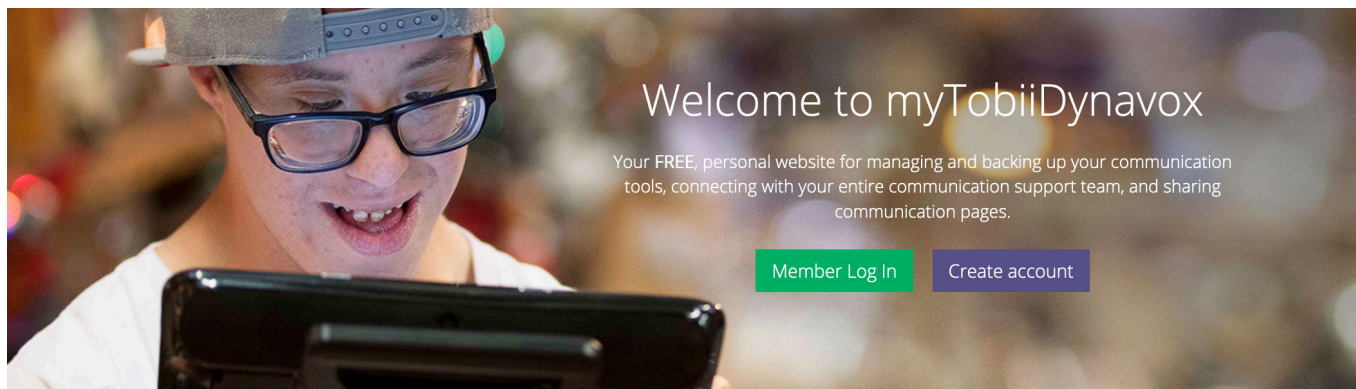

Welcome to myTobiiDynavox

Your FREE, personal website for managing and backing up your communication tools, connecting with your entire communication support team, and sharing communication pages.

Member Log In

Create account

Your free myTobiiDynavox.com account gives you access to numerous benefits including cloud storage for backups, Page Set Syncing and sharing, lesson plans and more!

Joining will allow you to:

- Safely back up your system
- Download free tools and resources
- Claim and manage companion licences
- Learn about available updates
- Access Tech Support and FAQs
- Share Page Sets and Page Bundles



myTobiiDynavox

myTobiiDynavox.com

Companion licences



Your TD Pilot comes with two companion licences for TD Snap[®]. The companion licences allow you to use TD Snap on additional Windows or iPadOS devices. The companion licences are claimed and managed through your myTobiiDynavox account.

Claim your TD Snap companion licences

- 1 On your TD Pilot device, sign into your myTobiiDynavox account in TD Snap.
(*Edit > User > myTobiiDynavox Account*)
- 2 On your companion device, install TD Snap. TD Snap installers are available at mytobiidynavox.com/Support/TDSnap and the Apple App Store.
- 3 On your companion device, open TD Snap and sign into the same myTobiiDynavox account.
(*Edit > User > myTobiiDynavox Account*)



Tip

Use your companion device to model AAC use and edit page sets so that you don't interrupt the AAC user on their own device.

Additional resources



TD Pilot User's Manual

qrco.de/PilotDocs



TD Facebook Community

qrco.de/TDFB



Software Training Cards

qrco.de/be9m4o



Product Warranties

qrco.de/wrtglbl



Documentation

TD CoPilot > Settings > Help



UK Technical Support

0114 481 0011

support.uk@tobiidynavox.com



Ireland Technical Support

Safe Care Technologies

021 2428566

hello@safecaretechnologies.com



Australia and New Zealand Technical Support

support.apac@tobiidynavox.com



Rest of the World Technical Support

Contact your local Tobii
Dynavox partner.

tobiidynavox.com/blogs/partner